

Prénom :

Date :







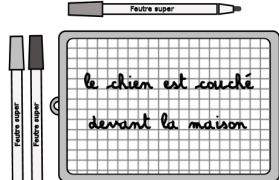
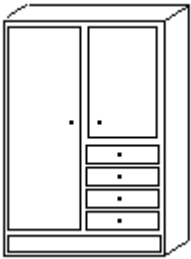
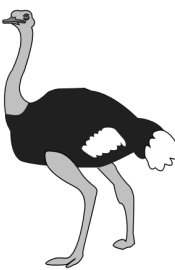

	Oi oi oi	
	OISEAU	
[oi]	oiseau	
	oiseau	

LECTURE : phonologie 1

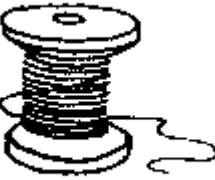
Je suis capable de repérer un son identique dans plusieurs mots.

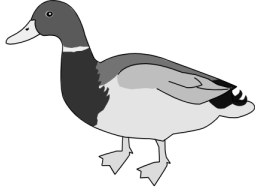

Je colorie l'image quand j'entends [oi].

LECTURE : phonologie 2

	OI oi oi	
	OISEAU	
[oi]	oiseau	
	oiseau	



Je suis capable de localiser un son dans un mot.

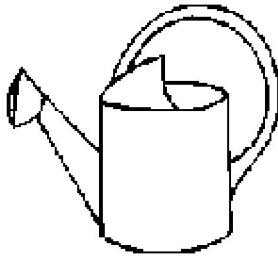
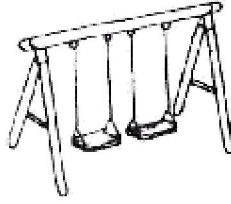
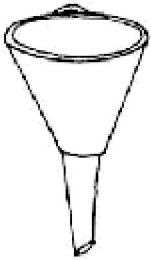

Je mets une croix où j'entends [oi].

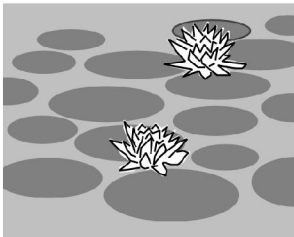
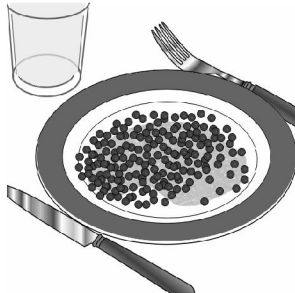
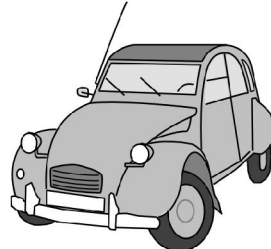
		
<input type="checkbox"/> <input type="checkbox"/> <input type="checkbox"/>	<input type="checkbox"/> <input type="checkbox"/> <input type="checkbox"/>	<input type="checkbox"/> <input type="checkbox"/> <input type="checkbox"/>

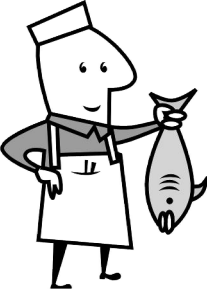
		
<input type="checkbox"/> <input type="checkbox"/> <input type="checkbox"/>	<input type="checkbox"/> <input type="checkbox"/> <input type="checkbox"/>	<input type="checkbox"/> <input type="checkbox"/> <input type="checkbox"/>

		
<input type="checkbox"/> <input type="checkbox"/> <input type="checkbox"/>	<input type="checkbox"/> <input type="checkbox"/> <input type="checkbox"/>	<input type="checkbox"/> <input type="checkbox"/> <input type="checkbox"/>

Prénom :

Date :

	OI oi oi	
	OISEAU	
[oi]	oiseau	
	oiseau	

LECTURE :

discrimination visuelle

Je connais les lettres de l'alphabet.

Je connais les correspondances entre minuscules et majuscules d'imprimerie et majuscules et minuscules cursives.



J'entoure quand je vois les lettres OI .

MOI GIO POJ IOL TOI QI
roi soi bio foj qio doi
taj pou mai sat sai loi



J'entoure les mots où je vois la lettre.

voiture

maison

froide

MOIS

QUOI

TROU

droit

trait

peinture



Je colorie les mots identiques de la même couleur.

voie	VOIE	VOIS
voisc	VOIX	voie
voit	voit	vois
VOIT	VOIX	VOIS



LECTURE : combinatoire

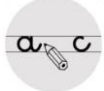

	OI oi oi
	OISEAU
[oi]	oiseau
	oiseau
	

Je suis capable de repérer les syllabes d'un mot.
 Je suis capable d'organiser des syllabes pour construire un mot.

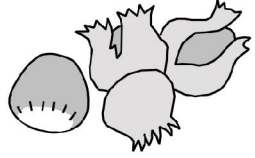

Je complète les mots avec : *poi, noi, roi, toi, coi*

		
___feur	mi___r	___settes

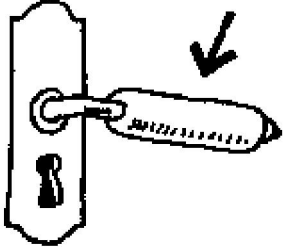
		
___reau	___ture	___gnée

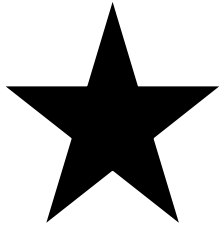
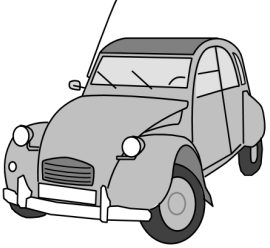

Je reconstruis les mots avec les syllabes.

le	é	toi	vai	re	tu
					
_ _ _ _ _			_ _ _ _ _		